

GEN2 20A 12V 2 Bank

Lead Acid
Wet Gel MF EFB AGM
Auto | Marine | RV | Powersport | Lawn & Garden

On-Board Battery Charger™



NOCO
Waterproof™

Charge Fully Drained Batteries Up To **230Ah/bank**. Maintain All Battery Sizes. Boats and a wide range of equipment. Perfect for harsh conditions.

Ultra-compact, rugged, and water proof, the fully-sealed charger can be mounted directly onto a variety of applications. Features **spark proof technology** and **reverse polarity protection**. Charges **2X faster** than ordinary chargers. Stay connected 24/7 with **zero overcharge**.



Firewall.

Multi-level safety barrier prevents unsafe and abnormal conditions.



Energy Save.

Minimizes energy consumption when full power is not needed.



Recovery.

Applies a high-voltage pulse charge when low-voltage, sulfation, or lost capacity is detected.



Optimization.

Stabilizes internal battery chemistry for increased performance and longevity.



Interactive.

Alters the charging process based on organic battery feedback.



Rugged.

Dirt, water, UV, impact and crush resistant.



Maintenance Plus.

Keeps the battery fully charged without over-charging, indefinitely.



Safe.

Protects against reverse polarity, sparks, over-charging, overcurrent, open-circuits and overheating.



Ignition Protected.

Non-ignited and temperature controlled for safe and worry-free operation.

Charge **12V** Batteries Up To 230Ah/bank. Maintain All Battery Sizes.

The NOCO Company
30339 Diamond Parkway, #102
Glenwillow, OH 44139 | USA
1.800.456.6626

no.co

NOCO
Since 1914

Understanding LED Lights

LED	Explanation		
Red Solid Charging	When the battery is charging, the CHARGE LED will be illuminated RED. The CHARGE LED will remain a solid RED color (not blinking) until the battery is fully charged.	Orange Solid Reverse Polarity	If a Reverse Polarity condition exists, the ORANGE ERROR LED will illuminate. This ERROR condition will be displayed whether the charger is plugged in or disconnected from an AC power source. Reverse the battery connections to fix this ERROR.
Green Solid Fully Charged	When the battery is fully charged, the CHARGE LED will be illuminated GREEN. The CHARGE LED will remain a solid GREEN color (not blinking) until either the battery charger is disconnected or the battery becomes discharged.	All Flashing Error Condition	If an ERROR condition exists, the Charge LED(s) will flash, and/or the ERROR LED will illuminate and/or flash. There are several reasons an ERROR condition could exist. For help troubleshooting ERROR conditions, see the section entitled TROUBLESHOOTING.
		Red/Green Alternating Standby	When no battery is connected, the LED lights will alternate between RED and GREEN.

Technical Specifications

Input Voltage AC:	110-120 VAC, 50-60Hz	Type of Batteries:	12V Lead-Acid
Working Voltage AC:	70-130 VAC, 50-60Hz	Battery Chemistries:	Wet, Gel, MF, AGM
Nominal Voltage:	12VDC x 2	Battery Capacity:	25-230Ah, Maintains All Battery Sizes
Efficiency:	90% Approx.	Housing Protection:	IP68
Charging Voltage:	14.4V	Cooling:	Natural Convection
Back Current Drain:	<5mA	Dimensions (LxWxH):	8.5 x 6.5 x 3.3 Inches
Ripple:	<2%	Weight:	8.7 Pounds
Charger Type:	8 Step, Fully Auto., Switch-Mode		

Charging Steps

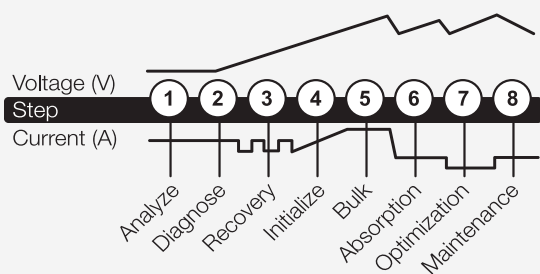

What's In The Box

- GEN2 Smart Charger
- Mounting Screws
- User Guide and Information Guide & Warranty

2 Bank 20A

12V + 12V
10A 10A

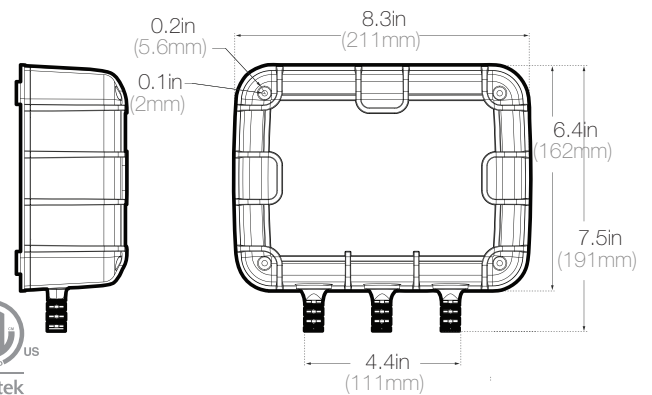

Charging Times

Battery Size (Ah)	Approx. Time (Hrs)	70	4.5
20	1.3	80	5.0
30	2.5	90	6.3
40	3.0	100	7.5
50	3.5	110	10.0
60	4.0	120	11.5

Retail Packaging:

Dimensions: 10.71"x8.98"x5.87"

Weight: 9.06lbs

UPC: 0-46221-09027-7

Inner Carton:

Dimensions: 11.02"x9.37"x6.30"

Weight: 9.66lbs

Master Carton:

Dimensions: 19.76"x11.81"x13.58"

Weight: 40.12lbs

Quantity: 4

UCC: 10046221090274

Units Per Pallet: 128 Units



Intertek
4001276

CONFORMS TO UL STD. UL1236
CERTIFIED TO CSA STD. C22.2 No.107.2

AC Cable: 72in

DC Cable: 78in

The NOCO Company
30339 Diamond Parkway, #102
Glenwillow, OH 44139 | USA
1.800.456.6626

noco

NOCO
Since 1914