

NOTES: UNLESS OTHERWISE SPECIFIED

1. SEE DRAWING NO. CB-00281 AND PROCEDURE P-1000 FOR ASSEMBLY AND TEST INSTRUCTION. PROCEDURES AND ASSEMBLY DRAWING ARE FOR INTERNAL USE ONLY.
2. ALL TESTING IS PERFORMED IAW BATTERY COUNCIL INTERNATIONAL STANDARDS.
3. ALL DIMENSIONS ARE IN INCHES [MM]
4. TERMINAL HARDWARE KIT PROVIDED, PART NUMBER 6923

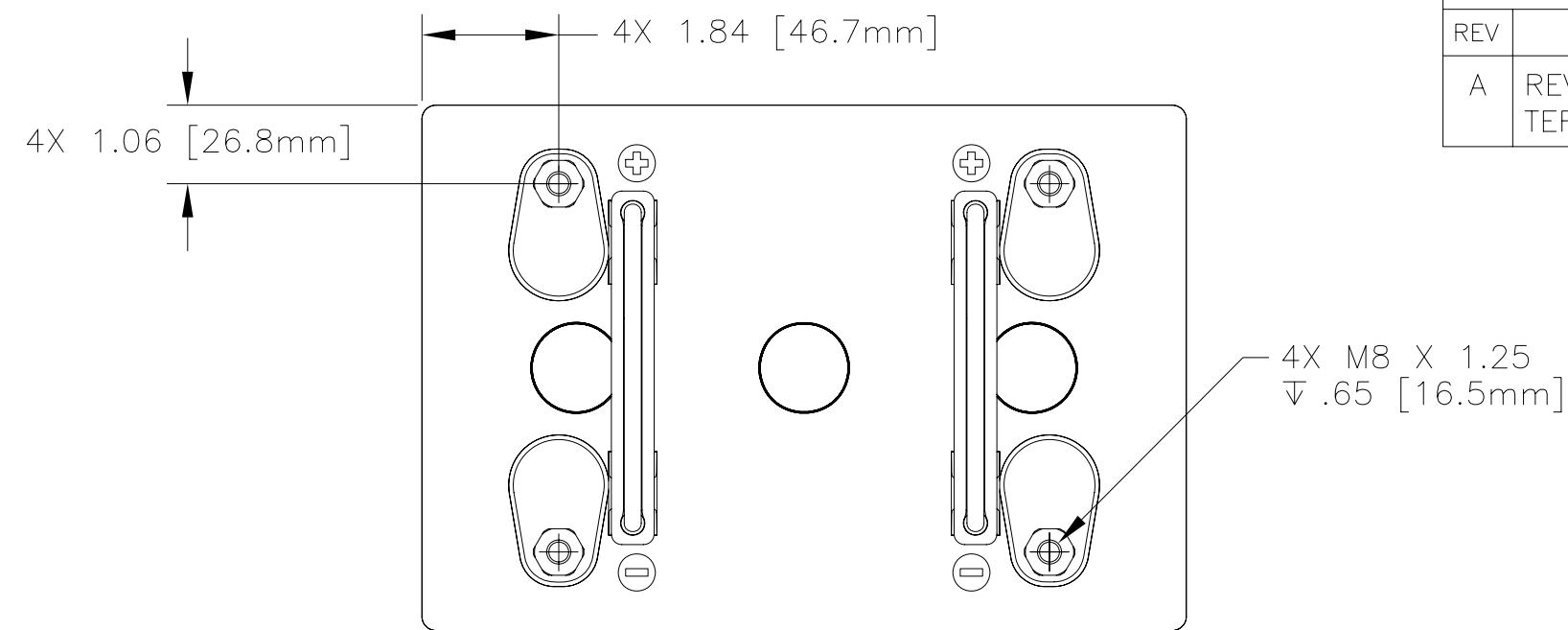

REVISIONS			
REV	DESCRIPTION	DATE	APPROVED
A	REVISED TERMINAL DAMS, TERMINAL HEIGHT & HANDLES	9/16/09	JBT

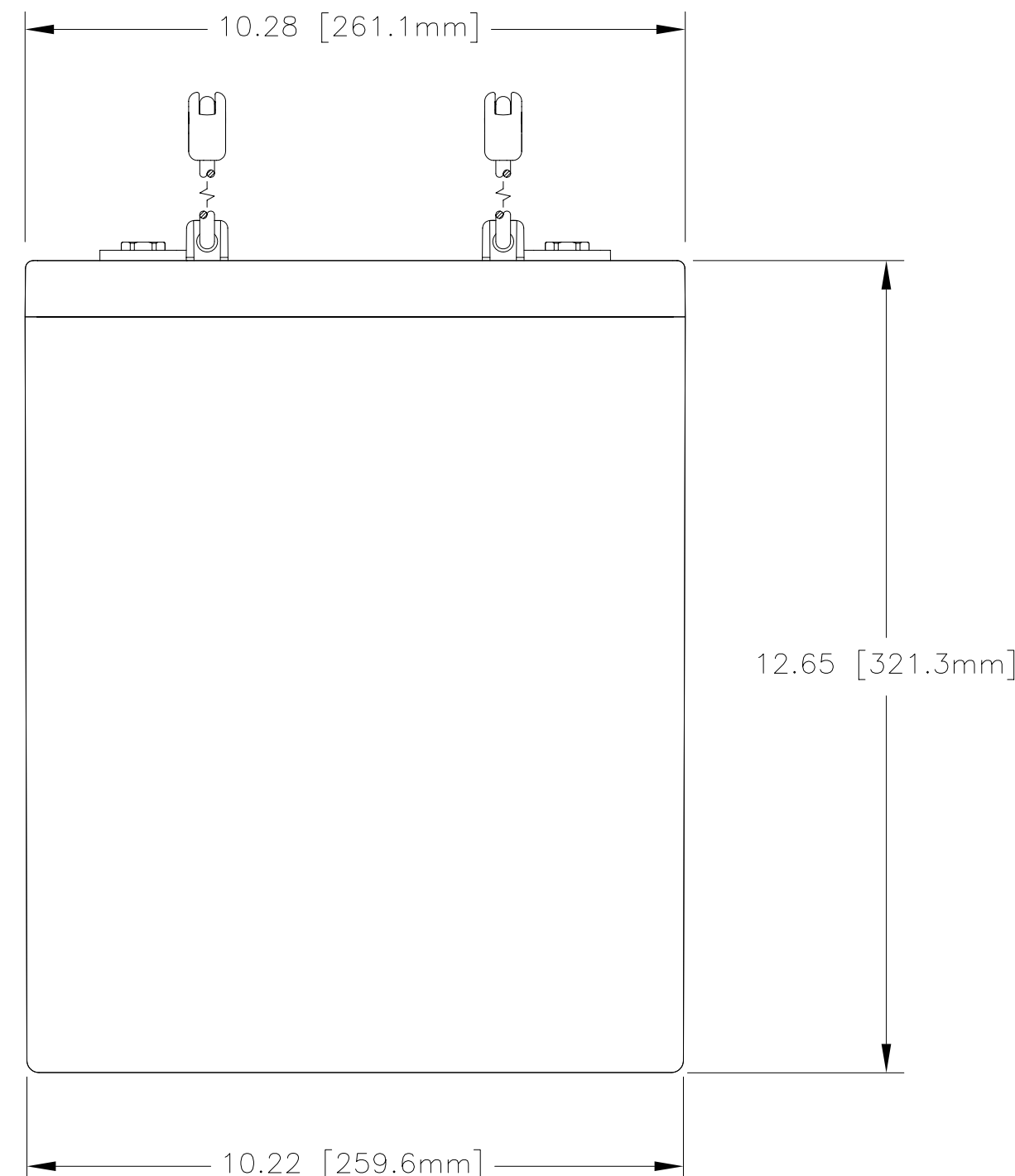
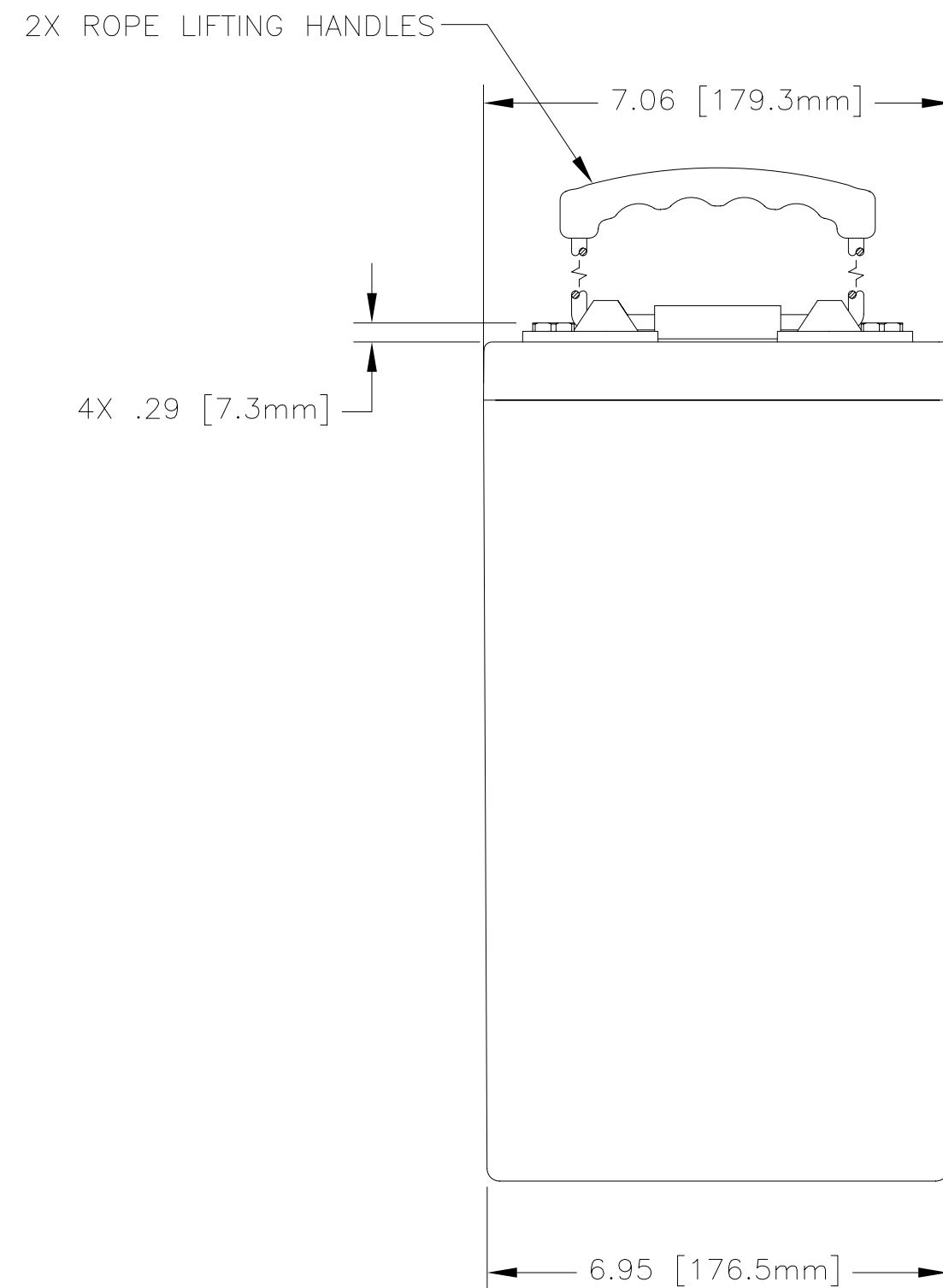

CAPACITY RATINGS

PART NUMBER	GPL-6CT-2V
NOMINAL WEIGHT	93 LBS [42.2 KG]
AMPERE HOUR CAPACITY @ 20 HOUR 1.75 VOLTS/CELL @ 77°F (25° C)	900 AH
MINUTES OF DISCHARGE @ 25 AMPS 1.75 VOLTS/CELL @ 77°F (25° C)	2076 MIN

ENVELOPE DRAWING

QTY REQD	CAGE CODE	PART OR IDENTIFYING NO.	NOMENCLATURE OR DESCRIPTION	MATERIAL SPECIFICATION	ITEM NO.
PARTS LIST					
UNLESS OTHERWISE SPECIFIED DIMENSIONS ARE IN INCHES TOLERANCES ARE:			CONCORDE BATTERY CORPORATION 2009 SAN BERNARDINO RD, W. COVINA, CA 91790		
FRACTIONS	DECIMALS	ANGLES	APPROVALS	DATE	TITLE
± 1/32	.XX ± .12	± 1°	DRAWN D. AYALA	1/25/08	BATTERY, 2 VOLT, GPL-6CT-2V
	.XXX ± .060		CHECKED AMIII	1/25/08	SIZE C
TREATMENT	NONE		APPROVED JBT	1/25/08	CAGE CODE 63017
FINISH	NONE		ISSUED JJ	9/18/09	DWG NO. GPL-6CT-2V
SIMILAR TO N/A	ACT WT N/A	CALC WT N/A			REV A
			SCALE 1=2.5	SHEET 1 OF 1	